

FLOOR-EQUIPMENT-PARTS.COM

Minuteman[®]
Excellence Meets Clean



**Parts and Instruction Manual
Lumina 20 Traction Drive
Battery Burnisher**

This manual is furnished with each new **MINUTEMAN Lumina 20**. This provides the necessary operating and preventive maintenance instructions. Operators must read and understand this manual before operating or servicing this machine.

This machine was designed to give you excellent performance and efficiency. For best results and minimal cost, please follow the general guidelines below:

- Operate the machine with reasonable care.
- Follow the manufacturers suggested maintenance instructions as provided in this booklet.
- Use original Minuteman supplied parts.

TECHNICAL SPECIFICATIONS

Model	<i>Lumina 20 Traction Drive</i>
Model No.	M26036TDQP / M26036TDCE
Brush Speed	2600 RPM
Motor	2.5HP
Voltage, Batteries	36 volts, 3-12volt
Battery Capacity	165 AH

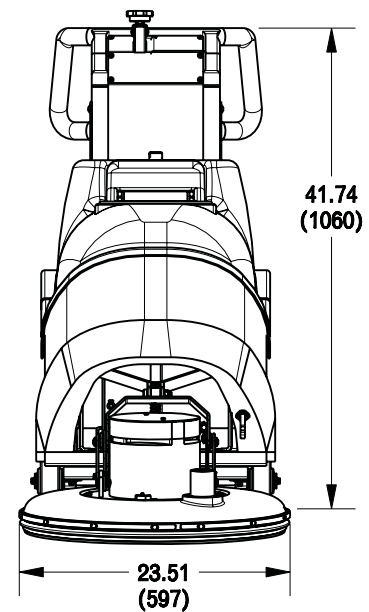
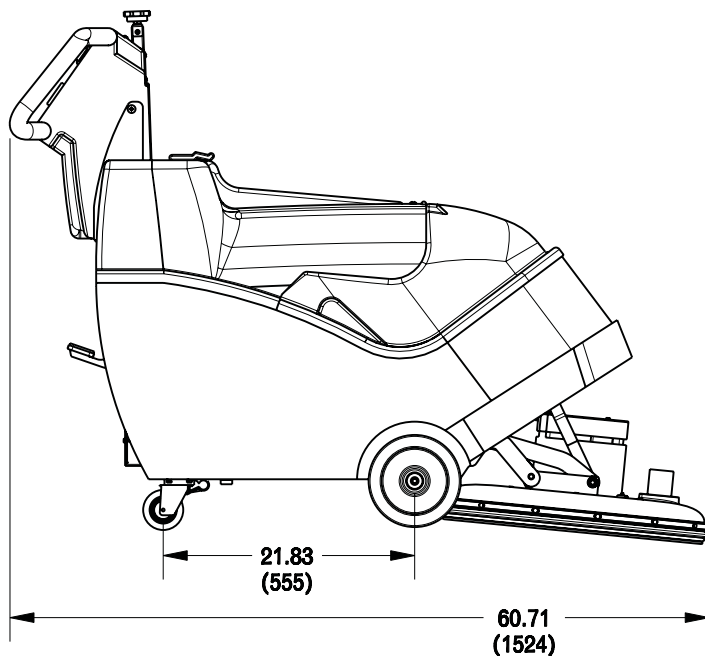

EC Declaration of Conformity

according to Directives 72/23, 89/392, and 89/336

We, Minuteman International Incorporated, of 111 South Rohlwing Road Addison Illinois 60101 USA, declare under our sole responsibility that the product M26036TDCE, M26036TDQPIW, M26036CE, Lumina Burnisher to which this declaration relates corresponds to the relevant requirements of the EC Directives 72/23, 89/392 and 89/336. The following standards were used to determine compliance with the Directives: EN 292, EN 294, EN 811, EN 55014, EN 55104 and EN 60335-1.

SOUND		VIBRATION												
73 dB Operator	69dB At 3m	.5 m/s² At Operators Handle												
Tests were conducted on 11/3/04 with calibrated sound and vibration equipment under the conditions noted below: <table style="width: 100%; margin-top: 10px;"> <tr> <td style="width: 33%;">General Condition:</td> <td style="width: 33%;">Indoors</td> <td style="width: 33%;">Wind:</td> <td style="width: 33%;">0 km/hr</td> </tr> <tr> <td>Temperature:</td> <td>25⁰C</td> <td>Humidity:</td> <td>70%</td> </tr> <tr> <td>Barometric Pressure:</td> <td>29.5</td> <td></td> <td></td> </tr> </table>			General Condition:	Indoors	Wind:	0 km/hr	Temperature:	25 ⁰ C	Humidity:	70%	Barometric Pressure:	29.5		
General Condition:	Indoors	Wind:	0 km/hr											
Temperature:	25 ⁰ C	Humidity:	70%											
Barometric Pressure:	29.5													



Jeff Pollack, Standards Engineer

11/03/04

Date

Form: EC053C

Table of Contents

IMPORTANT SAFETY INSTRUCTIONS	1
Operating Instructions	2
Inspection	2
Electrical	2
Batteries	2
Operation	2
After Use	3
Maintenance	3
Floor Seal Strip	3
Battery Service and Installation	3
Charging of Batteries	3
Battery Cable Routing	3
Pad Installation	4
Pad Pressure Adjustments	4
Circuit Breaker Protection	4
Carbon Brush Replacement	4
Carbon Brush Service	4
Machine Overview	5
Dashboard Control Panel	6
Exploded Views	7
Base Assembly	7
Base Assembly BOM	8
Mainframe Assembly	9
Mainframe Assembly BOM	10
Housing Assembly	11
Housing Assembly BOM	12
Pad Driver Assembly	13
Pad Driver Assembly BOM	14
Pressure Control Assembly	15
Electrical Assembly	16
Console Assembly	17
Console Assembly BOM	18
Dashboard Assembly	19
Wiring Diagram	20
Minuteman International Made Simple Commercial Limited Warranty	23

IMPORTANT SAFETY INSTRUCTIONS

CAUTION: Operators must read and understand this manual before operating or maintaining this machine.

Keep hands and feet clear of moving parts while machine is in operation.

Disconnect the power to the machine by pressing the Red Emergency Disconnect Button when charging batteries or during installation or removal of pads.

During operation, loose objects on the floor can become dangerous projectiles if struck by the high speed pad. Special attention should be paid in removing or avoiding loose floor tile, electrical cables and telephone connection boxes.

Electrical motors and components can cause an explosion when operated near explosive materials or vapors. Do not operate this machine near flammable materials such as solvents, thinners, fuels, grain dust, etc.

Keep machine moving to reduce the risk of damaging floor finish and floor.

Make sure the Red Emergency Disconnect Button is pressed and the battery connector is unplugged from the machine before performing any maintenance procedures.

Store or park this machine on a level surface only.

These machines are designed for level floor operation only. Do not operate on ramps or inclines.

Battery acid can cause burns. When working on or around batteries, wear protective clothing and safety glasses. Remove metal jewelry. Do not lay tools or metal objects on top of batteries.

Charging batteries generates explosive gases. **DO NOT CHARGE BATTERIES WHEN OPEN FLAMES OR SPARKS ARE PRESENT. DO NOT SMOKE.** Make sure the charger is turned off before disconnecting it from the machine. Charge the batteries in a well-ventilated area with the battery cover removed completely.

Maintenance and repairs must be performed by authorized personnel.

SAVE THESE INSTRUCTIONS

Operating Instructions

Inspection

Carefully unpack and inspect your burnisher for shipping damage. Each unit is tested and thoroughly inspected before shipment; any damage is the responsibility of the delivery carrier who should be notified immediately.

Electrical

This machine is battery operated and designed to operate on 36 volts DC (3) 12 volt batteries.

Batteries

Burnishers are shipped with batteries. (3 required)

Part No. 956210 12V 210AH 20 Hr. Rate

We do not recommend mixing AMP hour capacities. Any alternate battery sets can be used if they equal physical size and capacity. See next page for service and installation.

Operation

Before starting, familiarize yourself with the machine and its controls (see “Machine Overview” and “Dashboard Control Panel” diagrams). To turn the machine ON, do the following:

- 1. Make sure 20" high speed pad is used. Make sure the pad is installed on the machine by following instructions under “Pad Installation.”*
- 2. Make sure that no battery charger is plugged into the recharge port.*
- 3. Lift the red emergency disconnect button so it is in the up position.*
- 4. Lower the pad driver assembly by pushing the pedal slightly outward on the machine (unlock it), and then release it slowly.*
- 5. Turn the key switch to the ON position. The pad driver will then slowly adjust itself to the floor. Make sure the machine is set to move forward indicated by the light on the dashboard control panel.*
- 6. Place hands on the bails and squeeze the bail levers to start the operation of the machine. Move forward in a straight line, check the reading on the Operating Range Meter and make sure you are in the Green Zone.*
- 7. Adjust the pad pressure as needed by turning the knob accordingly. (See Pad Pressure Adjustments.)*
- 8. Adjust speed as needed by turning the speed control knob accordingly.*

After Use

To raise the pad driver, push down until the pedal arm engages into the pedal catch. Turn machine off by turning the key switch on the control panel. Machine can be cleaned with a mild detergent and a damp cloth. Batteries should be charged after each use or when the battery condition meter shows a low charge. Once the battery charger reads 0 amps, the batteries are recharged. This should take approximately 8 hours if the batteries are completely discharged.

Maintenance

Periodically remove batteries from machine. Clean the batteries and battery tray with a solution of baking soda and water. Check all battery cables and wiring for signs of damage and wear. Replace as needed. Grease front wheel and rear caster zerks once a month for best operation.

Floor Seal Strip

When the floor seal strip show signs of excessive wear, seal should be replaced. The strip can be removed by loosening the screw on the retainer strap until the seal can slide off of the pad shroud housing. To install new seal, slip the retainer strap over the new seal strip and pad shroud. Make sure the seal is seated equally around the perimeter and the holes on the floor seal are oriented towards the back portion of the shroud.

Battery Service and Installation

WARNING: Battery acid can cause burns. When working on or around batteries, wear protective clothing and safety glasses. Remove metal jewelry. Do not lay tools or metal objects on top of batteries.

Charging of Batteries

Charging batteries generates explosive gasses. **DO NOT CHARGE BATTERIES WHEN OPEN FLAMES OR SPARKS ARE PRESENT. DO NOT SMOKE.** Make sure the charger is turned off before disconnecting it from the batteries. Charge the batteries in a well-ventilated area with battery cover removed completely. Fluid levels should be checked before and after charging and maintained at the proper levels. If the burnisher is not used for extended periods of time, batteries should be kept fully charged with a boost charge once a week.

Battery Cable Routing

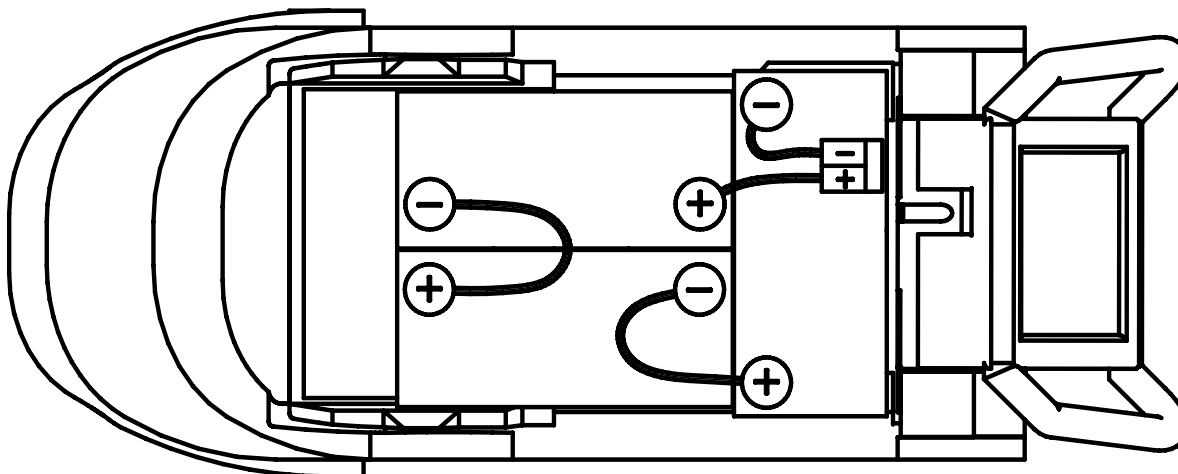

Pad Installation

The red emergency disconnect button and the key switch must be in the OFF position before installation and the pad driver assembly in the RAISED position. Remove center cup locking device by gripping on outer edges and turning clockwise. NOTE: Center cup cannot be pulled out; it must be unscrewed. After removing used pad, place new pad on pad driver assembly using outer flange of pad driver to center the pad. Push centering locking cup through the pad and into the pad driver assembly. The ratchet teeth on the center cup will engage into the pad driver assembly and should be pushed in as far as possible. If further tightening is needed, rotate the center-locking cup counter-clockwise

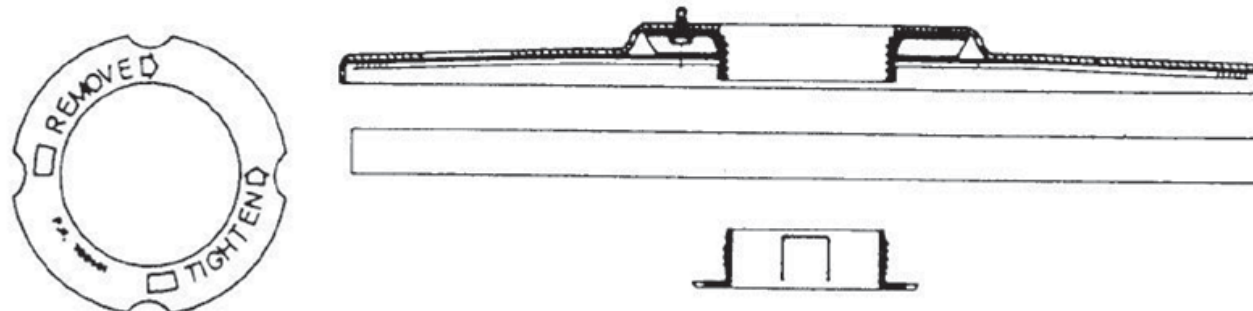

Pad Pressure Adjustments

The pad pressure adjust knob is located on the top of the control console. Counter-clockwise rotation increases pad pressure, the opposite rotation decreases. Different floors, conditions, and pads produce carrying pad load conditions. Ideal burnishing conditions are maintained while the operating range meter remains in the Green Zone. If the meter reads in the Red Zone decrease the pad pressure. When the machine is operated in the Red Zone for a long period of time motor overload will occur and the 70-amp circuit breaker for the motor will trip. If the motor circuit trips:

1. Check pad condition.
2. Decrease pad pressure.
3. Reset circuit breaker.

Circuit Breaker Protection

70 amp circuit breaker protects pad driver motor from excessive overload conditions. 3.0 amp circuit breaker protects control circuits against possible electrical shorts. If either circuit breaker trips, first determine the cause and correct the condition before resetting the breakers.

Carbon Brush Replacement

Design life of carbon brushes is between 1800-2000 hours. Replace brushes if worn to 3/8" or less, broken, or chipped. All carbon brushes should be replaced when motor is serviced. Four (4) are required, P/N 572003. Red indicator on control panel (above Emergency Disconnect Button, below the Dashboard) will glow when carbon brush service is required.

Carbon Brush Service

1. Disconnect batteries from machine.
2. Remove two screws that hold dust control housing and motor cover to motor.
3. Blow out top of motor with air line.
4. Loosen screw and remove carbon brush lead.
5. Slide brush spring off the back of carbon brush and remove brush.
6. Reverse order for installation of new carbon brushes.

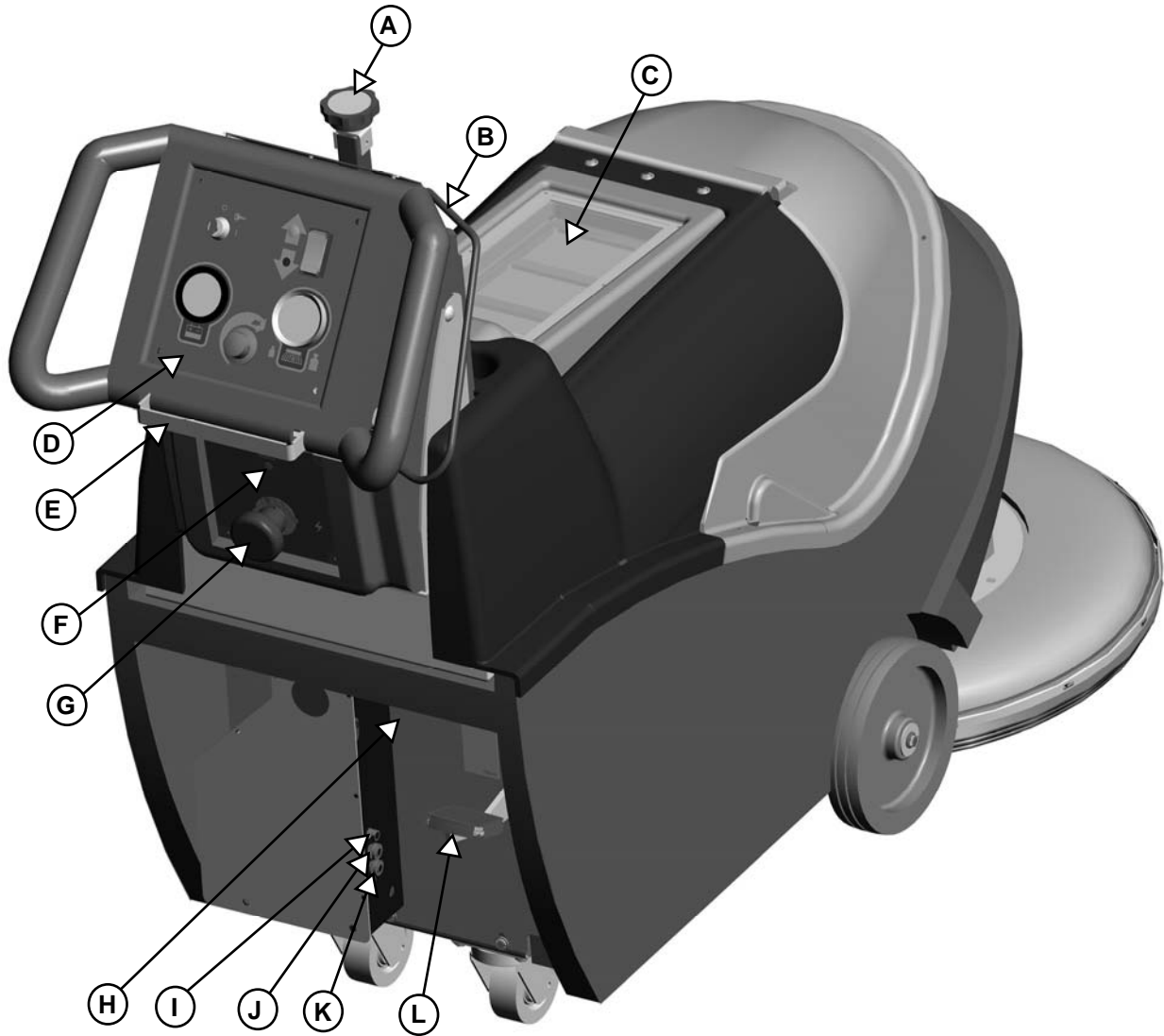

- A PAD PRESSURE ADJUSTMENT
- B BAIL LEVER
- C DUST BAG
- D DASHBOARD CONTROL PANEL
- E EMERGENCY BELLY BAR STOP
- F CARBON BRUSH INDICATOR

- G EMERGENCY STOP BUTTON
- H POWER CONNECTOR
- I CIRCUIT BREAKER, 70 AMP
- J CIRCUIT BREAKER, 3 AMP
- K CIRCUIT BREAKER, 18 AMP
- L FOOT PEDAL

Dashboard Control Panel

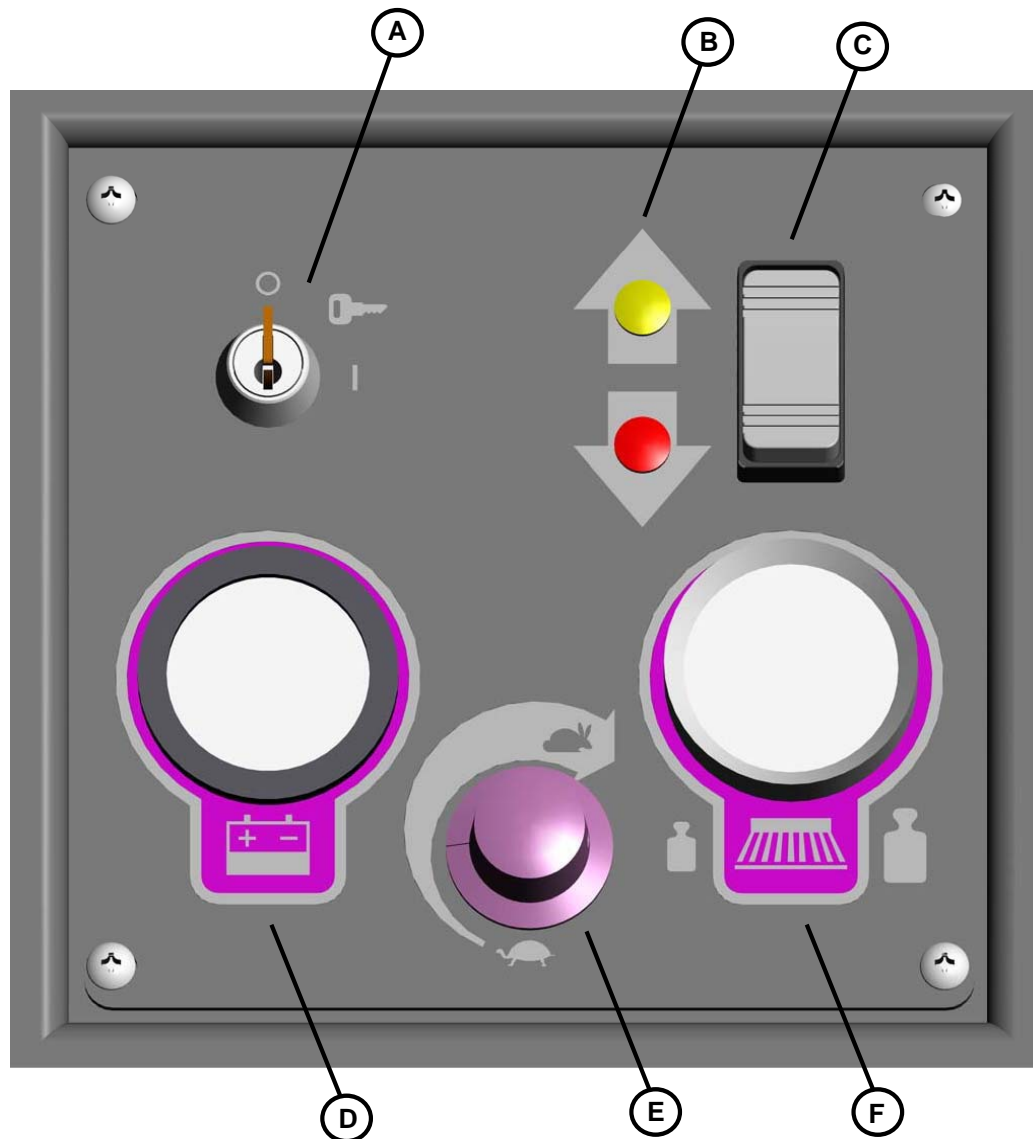

- A ON / OFF KEY SWITCH
- B TRACTION DRIVE DIRECTION INDICATOR
- C TRACTION DRIVE DIRECTIONAL SWITCH
- D BATTERY GUAGE
- E TRACTION DRIVE SPEED CONTROL
- F PAD PRESSURE GUAGE

Exploded Views

Base Assembly

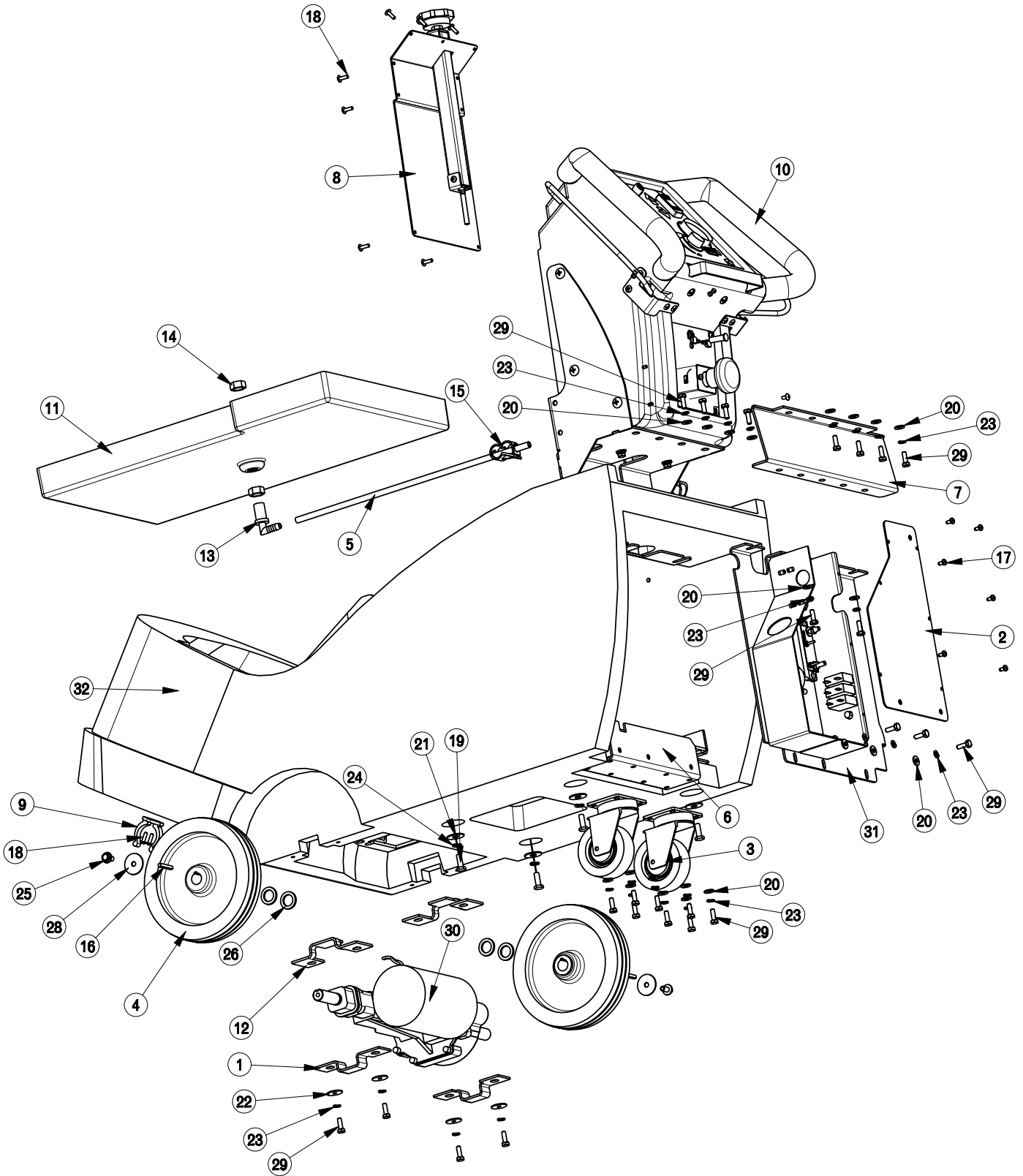

Base Assembly BOM

BILL OF MATERIAL			
ITEM	PART NO.	REQ'D	DESCRIPTION
1	200126	2	MOUNT, TRANSAXLE
2	200154	1	PANEL COVER WELDMENT
3	200345	2	CASTER, 3-1/2 POLYURETHANE
4	210141	2	WHEEL 8 X 1.5 X .75 BORE
5	260224	1	18" HOSE
6	260536	1	BASE PLATE WELDMENT
7	260541	1	REAR HANDLE BRKT
8	260549	1	PRESSURE ADJ ASSEMBLY
9	260579	1	TOOL CLIP, 1.5" HOSE
10	260583-1	1	CONSOLE ASY, 2600TD SPE BAT GA
11	260604	1	BATTERY BOX
12	260676	2	SPACER, TRANSAXLE
13	320271	1	NOZZLE BODY-ELBOW
14	320272	2	NOZZLE BODY LOCKNUT
15	320273	1	HOSE SHUT-OFF CLAMP
16	361233	2	KEY, 3/16 SQ. X 1.50"
17	711124	6	PAN HEAD ST #10 X .37 NI
18	711160	11	#10 X 5/8 HI-LO
19	711229	4	BLT-HH 5/16-18 x .875
20	711505	23	WSR-FLAT 1/4
21	711507	4	WSR-FLAT .37 X 1.12 X .06
22	711519	10	WSR- FLAT .25 X 1.01 X .06
23	711544	27	WSR-HELICAL 1/4
24	711545	4	WSR-HELICAL 5/16
25	712042	2	BLT-WSR HH 5/16-18 X .62
26	712318	4	WSR- FLAT.75 X 1.12 X .12 PL
27	712565	6	SCR-MC 1/4-20X.63 SS TR HD
28	712759	2	WSR- FLT .31 X 1.37 X .06 SS
29	713002	27	BLT-HH 1/4-20 UNC-2A X 3/4 STL#5
30	743800	1	TRANSAXLE 36VDC
31	743831	1	BURN ELECTRICAL ASSY
32	200102MCH	1	BASE MACHINED

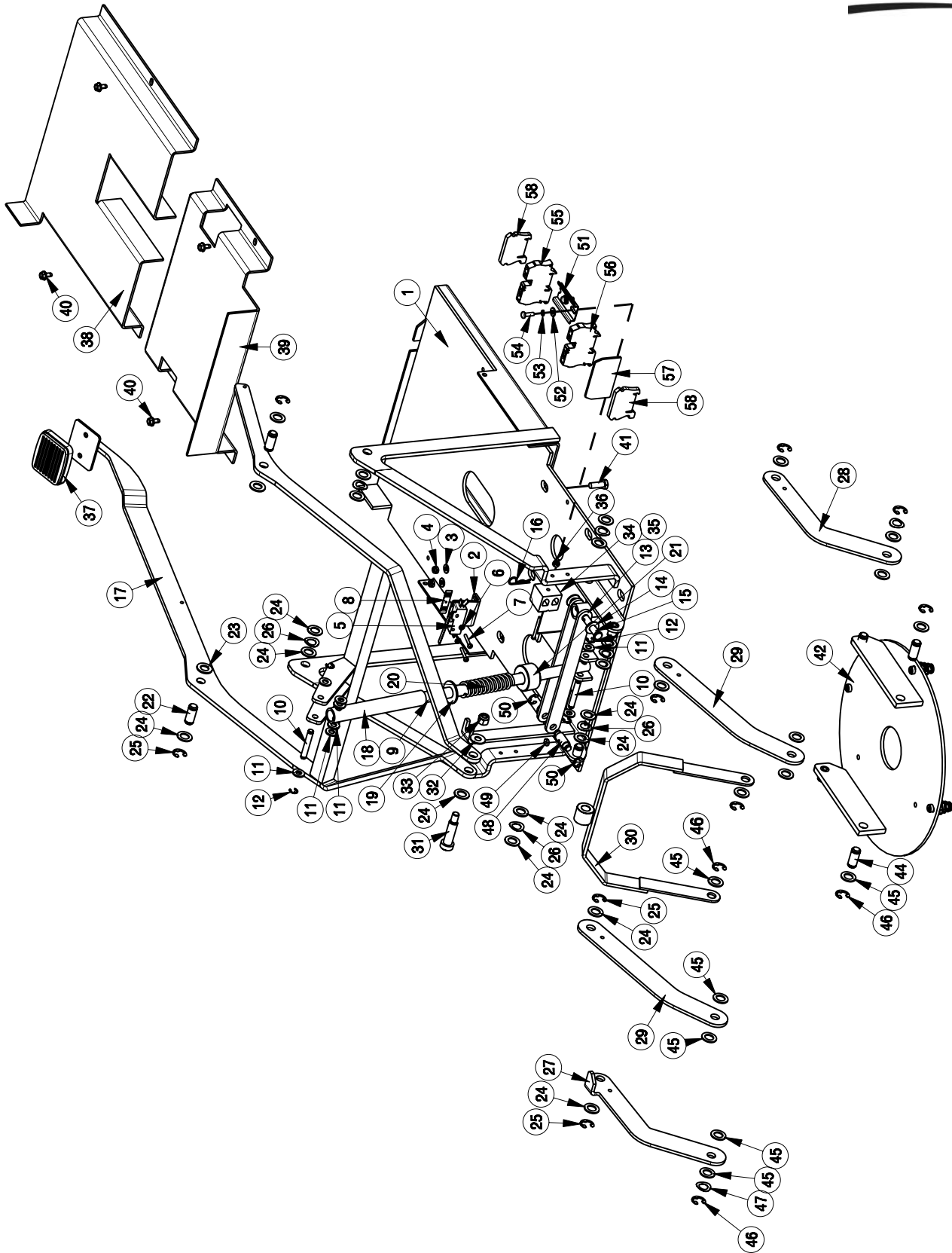

BILL OF MATERIAL			
ITEM NO.	PART NO.	QTY.	DESCRIPTION
1	260536	1	BASE PLATE WELDMENT
2	260577-1	1	SWITCH INTERLOCK BRACKET
3	711503	2	WSR, FLAT#10
4	711350	2	NUT NYLOC 10-32
5	740830	1	SWITCH SPST NC CONTACT
6	711501	2	WSR-FLAT # 6
7	710307	2	SCR-MC 6-32 X 1.0 ST PL PAN HD
8	711430	1	NUT-TINNERMAN TWIN 6-32
9	260522	1	SPRING GUIDE
10	670605	2	ROLLER PIN
11	711506	8	WSR-FLT .344 X .690 X .062 STL ZINC
12	711721	4	RET RING-E TYPE .312
13	260524	2	ADJUSTMENT LINK
14	711515	2	WSR-FLAT .406 X .812 X .0625
15	831965	1	3/8 x 1.63" CLEVIS PIN
16	711808	1	COTTER PIN-HAIR #13
17	260511	1	UPPER WMT
18	260521	1	GUIDE TUBE
19	711511	1	WSR-FLAT .62 X 1.31 X .09
20	762339	1	SPRING COMPRESSION
21	260523	1	SPRING SPACER 1.50 X .632 X .84
22	260519	2	PIVOT PIN
23	711592	2	WSR-FLAT .50 X .9 X .075 NYL
24	712310	19	WSR- FLAT .52 X .87 X .06 PL
25	711713	6	RETAINING RING - "E" TYPE EXT .500
26	711524	6	WSR-WAVE .52 X .87 X .01
27	260576	1	LINK
28	260528	1	LINK
29	260529	2	TRAILING LINK
30	260513	1	MOTOR LIFT WELDMENT
31	712102	1	BLT- SHLDR 1/2 X 1-1/2
32	712301	1	WSR-FLAT .87 X .38 X .06
33	711380	1	NUT-NYLOC 3/8-16 NUT
34	743598	1	TERMINAL BLOCK, 2 POS
35	710036	1	SCR-MC 8-32 X 1.50 ST PL
36	711372	1	NUT-NYLOC 8-32 STL ZINC
37	210142	1	PEDAL PAD
38	260586	1	SUPPORT, BATTERY LOWER
39	260587	1	SUPPORT, BATTERY UPPER
40	712139	4	SCR-TR 1/4-20X 1.00 HWH
41	711229	4	BLT-HH 5/16-18 x .875
42	260615	1	MOTOR PLATE WELDMENT - NEW
43	708	1	RTV SILICONE 10 OZ TUBE
44	260519	2	PIVOT PIN
45	712310	12	WSR- FLAT .52 X .87 X .06 PL
46	711713	5	RETAINING RING - "E" TYPE EXT .500
47	711524	2	WSR-WAVE .52 X .87 X .01
48	260525	1	ADJUSTMENT NUT
49	712905	1	NUT-HEX 10-24 NIPL
50	711717	2	RETAINING RING- E TYPE .37
51	743644	1	DIN RAIL, CUT - 2.00"
52	711503	2	WSR, FLAT#10
53	711543	2	WSR - HELICAL #10
54	710356	2	SCR-MC 10-32X.62 STPL
55	743640	1	TERMINAL BLOCK, RED (SPRING TYPE)
56	743641	1	TERMINAL BLOCK, BLACK (SPRING TYPE)
57	743642	1	TERM BLOCK, END PLATE
58	743643	2	TERM BLOCK, ANCHOR

Housing Assembly

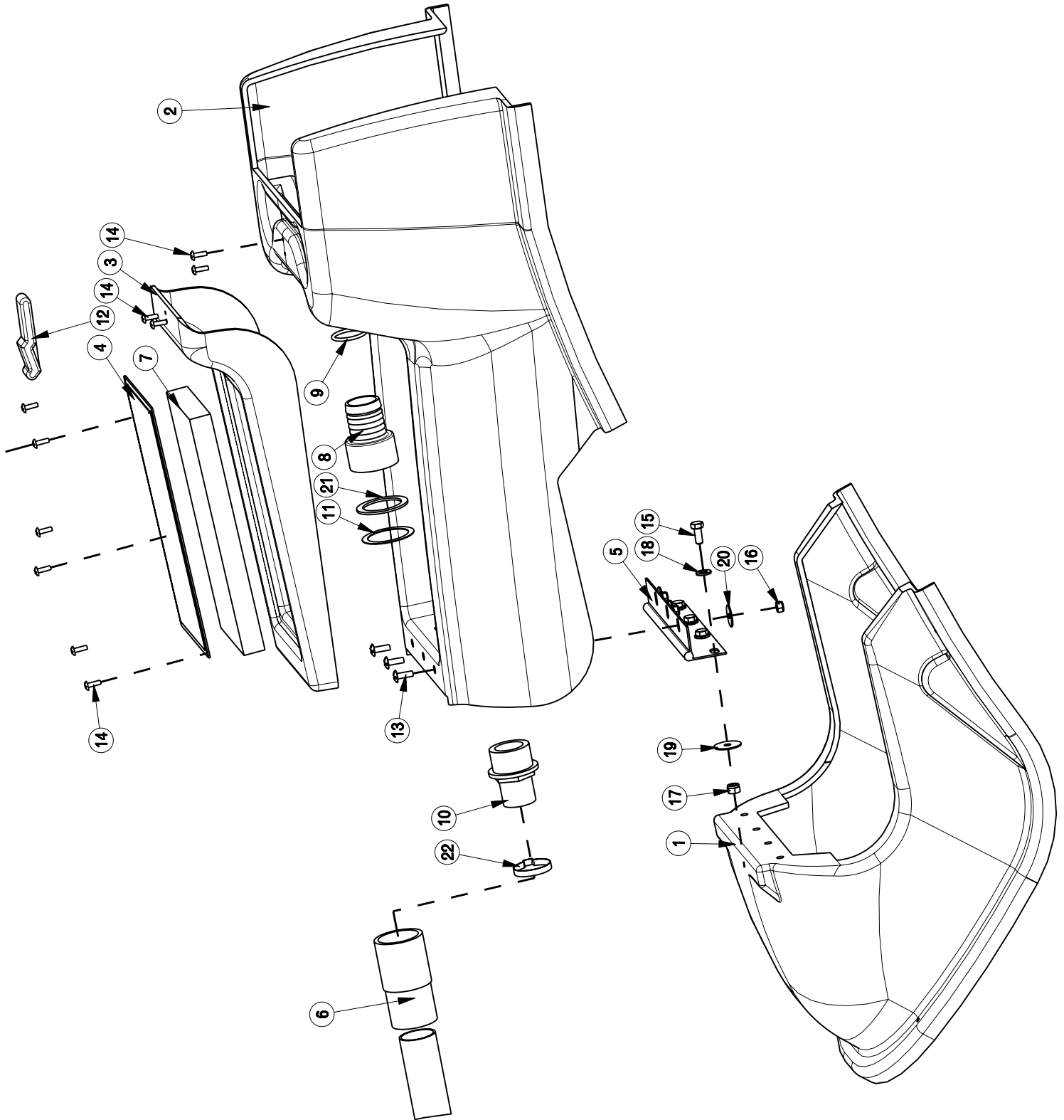

Housing Assembly BOM

BILL OF MATERIAL			
ITEM	PART NO.	REQ'D	DESCRIPTION
1	260501	1	FIXED TOP COVER
2	260502	1	MOVING TOP COVER
3	260503	1	BAG COVER
4	260504	1	FILTER COVER WELDMENT
5	260560	1	HINGE 9.75"
6	260590	1	HOSE ASSY DUST CONTROL
7	260592	1	EXHAUST FILTER DUST CONTROL
8	260596	1	INSERT FITTING, 1-1/2" PVC, FPT
9	310008	1	O RING BUNA 2201510561
10	450037	1	ADAPTER MACHINED
11	450081	1	WSR-SS 1.908 x 2.41 x .03
12	450207	1	LATCH, SOFT #C7-10
13	710180	3	SCR-MC TR HD 1/4-20x.75 STL ZINC
14	711160	10	#10 X 5/8 HI-LO
15	711228	4	BLT-HH 5/16-18 X .75 ST PL
16	711373	3	NUT-NYLOC 1/4-20
17	711374	4	NUT-NYLOC 5/16-18
18	711506	4	WSR-FLT .344 X .690 X .062 STL ZINC
19	711516	4	WSR- FLAT .31 X 1.25 X .05
20	711519	3	WSR- FLAT .25 X 1.01 X .06
21	828970	1	WSR-NEOP 1.87 X 2.4 X .125
22	831001	1	CRIMP CLAMP, 440R

Pad Driver Assembly

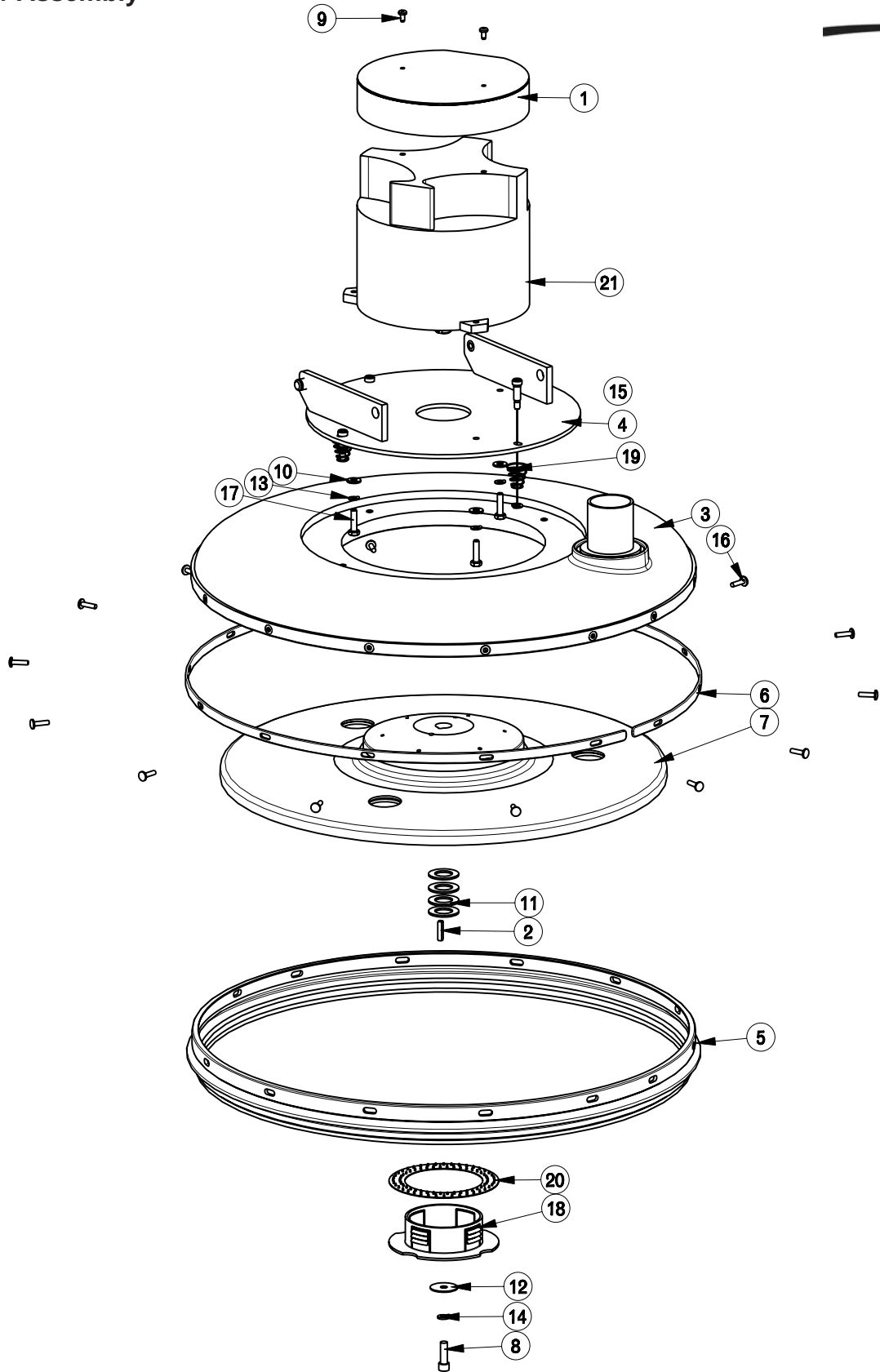

Pad Driver Assembly BOM

BILL OF MATERIAL - 260610			
ITEM	PART NO.	REQ'D	DESCRIPTION
1	260573	1	MOTOR GRILL ASSY
2	260597	1	KEY, 3/16 X .906
3	260611	1	PAD DRIVER SHROUD - 20"
4	260615	1	MOTOR PLATE WELDMENT - NEW
5	260616	1	DUST SKIRT - NEW
6	260619	2	PAD DRIVER STRAP
7	670075	1	PAD DRIVER ASSY
8	710857	1	SCR-SC 5/16-24 X 1.00
9	711124	2	PAN HEAD ST #10 X .37 NI
10	711505	3	WSR-FLAT 1/4
11	711512	4	WSR-FLAT .75X1.37X.08
12	711516	1	WSR- FLAT .31 X 1.25 X .05
13	711544	7	WSR-HELICAL 1/4
14	711545	1	WSR-HELICAL 5/16
15	712070	4	BLT, SHLDR 5/16 X .75
16	712537	14	10-24 X .75 SS TRUSS HD SCR
17	713003	3	BLT-HH 1/4-20 X 1 #5
18	760401	1	CENTER CUP, NEW STYLE
19	809857	4	TRIGGER SPRING
20	260581MCH	1	GRABBER RING, MACHINED
21	742461-2	1	MOTOR 66 FRAME 36V HI SPD

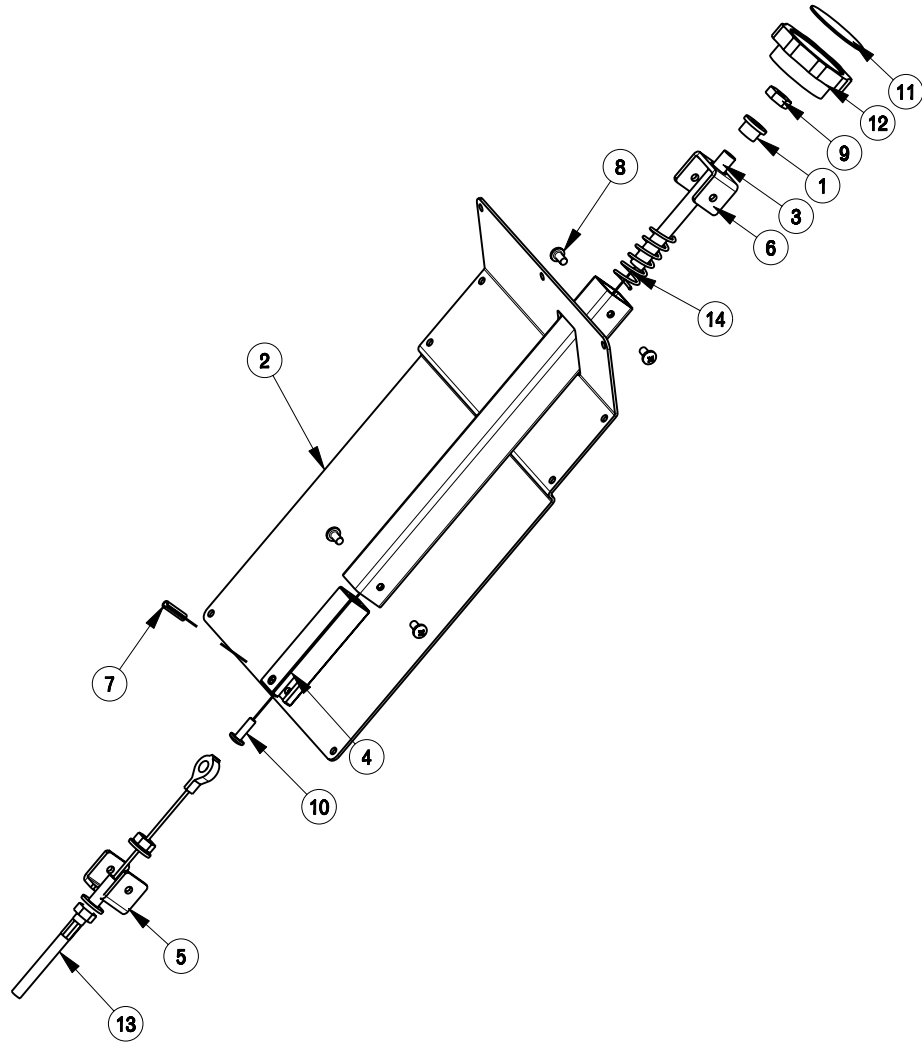

BILL OF MATERIAL - 260549

ITEM	PART NO.	REQ'D	DESCRIPTION
1	260066	1	OILITE BUSHING
2	260547	1	PRESS ADJ MOUNT WELD
3	260554	1	PRESS ADJ SCREW
4	260557	1	PRESS ADJ SLIDE
5	260562	1	PRESS ADJ RET BRKT
6	260563	1	PRESS ADJ RET BRKT
7	260564	1	ROLL PIN 3/16"X3/4"
8	710353	4	SCR-MC 10-32 X .37 ST PL
9	711391	1	NUT-HEX JAM 3/8-16 ST PL
10	712536	1	SCR-MC 10-24 X .62 TH SS
11	715038	1	DECAL, PAD PRESSURE
12	760034	1	KNOB, ADJ (SET SCREW)
13	762253	1	CABLE, ASSY PRESSURE
14	833102	1	SPRING, .62 X .75 X 1.75

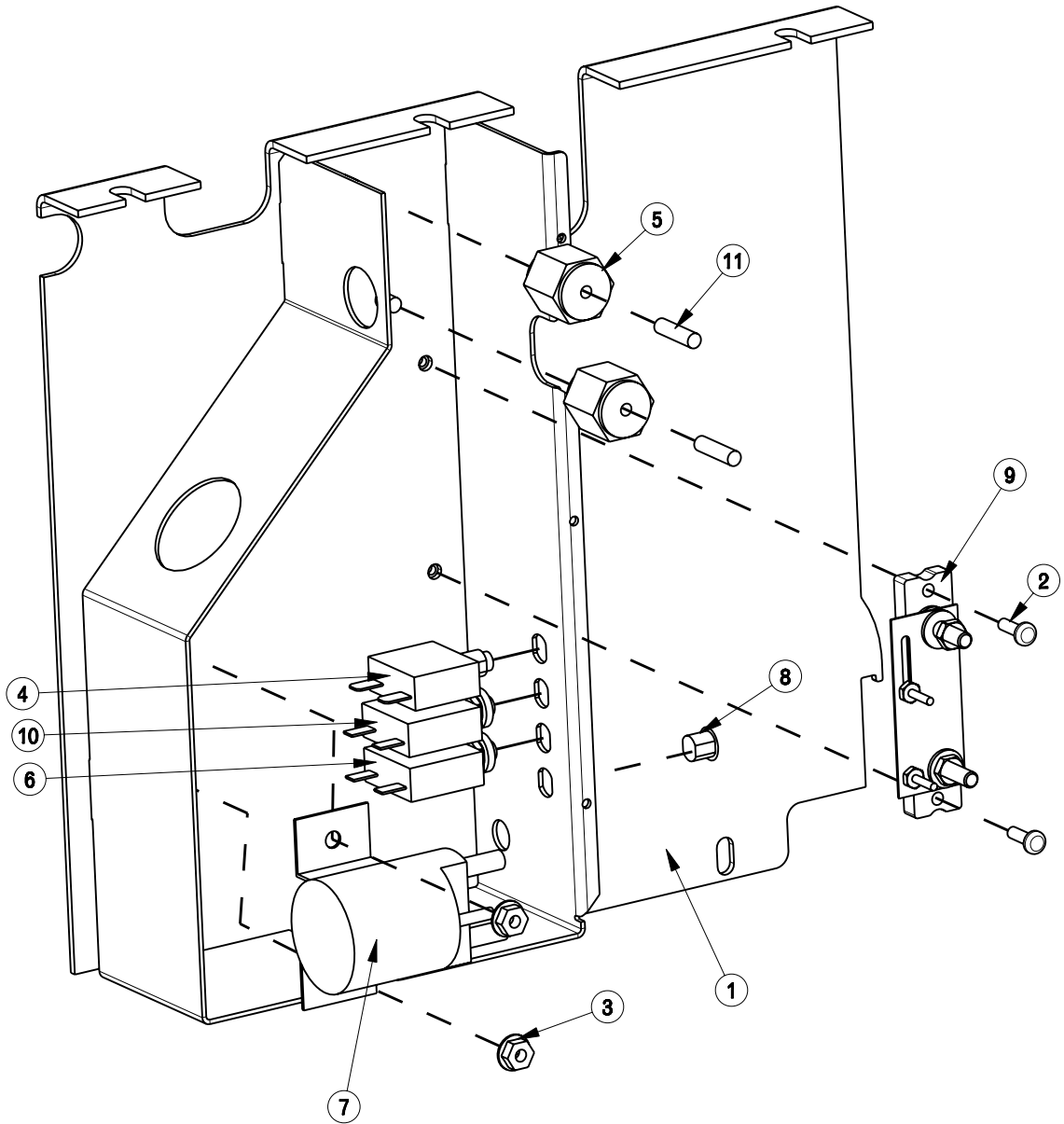

BILL OF MATERIAL - 260588

ITEM	PART NO.	REQ'D	DESCRIPTION
1	260542	1	BACK PANEL WELDMENT
2	710356	2	SCR-MC 10-32X.62 STPL
3	711425	2	NUT, HEX 1/4-20 WIZNUT
4	740131	1	CIRCUIT BREAKER - 70AMP
5	740132	2	INSULATOR, PLASTIC
6	740238	1	CIRCUIT BREAKER - 18A
7	740243	1	CONTACTOR 36V 124-117111
8	742749	1	HEYCO, HOLE PLUG
9	743464	1	SHUNT CALIBRATED ASSY
10	746006	1	CIRCUIT BREAKER - 3A
11	833638	2	BRASS STUD

Console Assembly

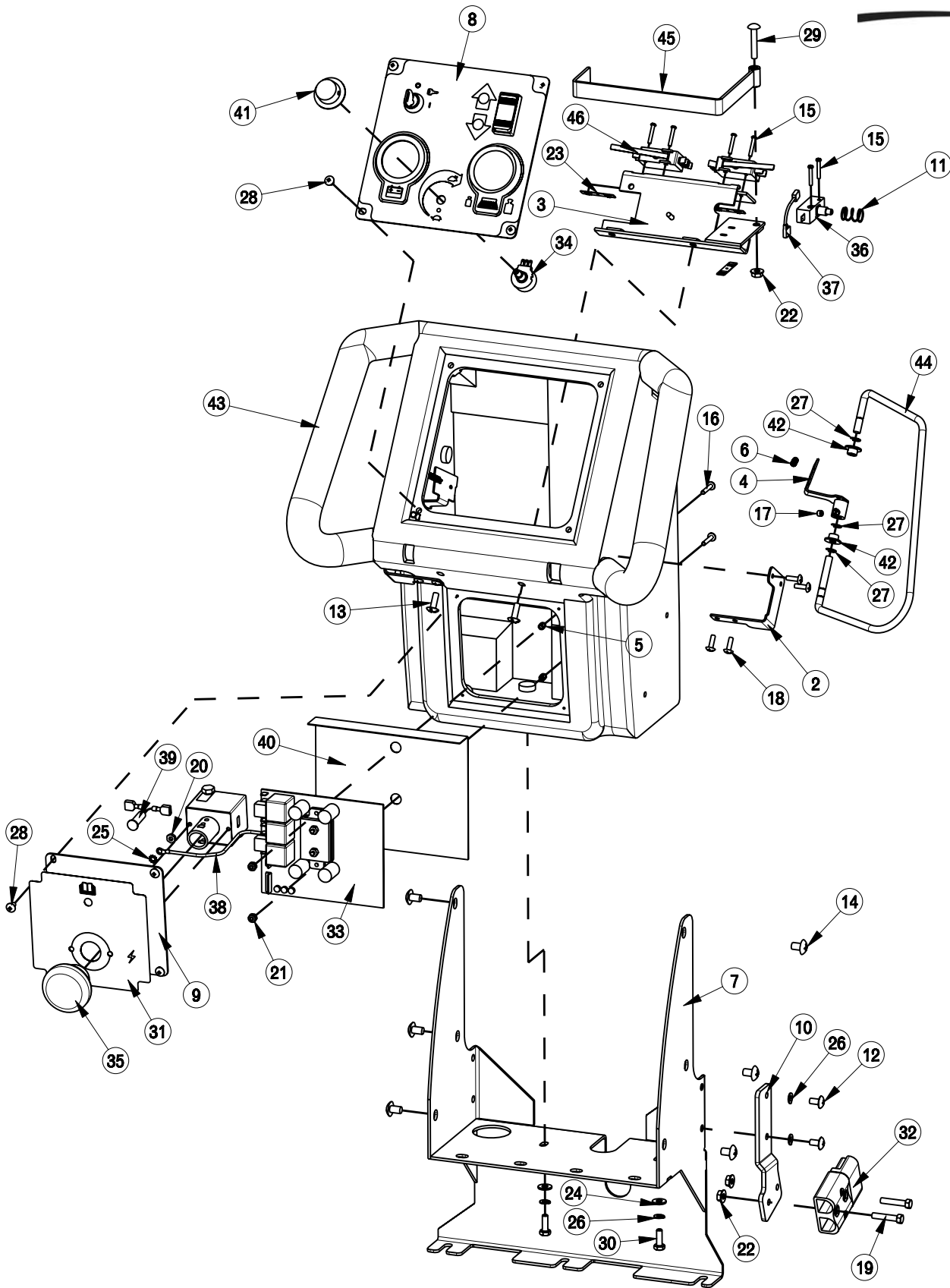

BILL OF MATERIAL - 260583-1			
ITEM	PART NO.	REQ'D	DESCRIPTION
1	200039	1	BAIL STOP RH
2	200040	1	BAIL STOP LH
3	200184	1	SWITCH BRACKET WELDMENT
4	200338	2	CAM WELDMENT
5	200340	2	SPACER, SCR BOARD
6	220324	2	SPRING
7	260538	1	FRONT BRKT HANDLE WELDMT
8	260584-1	1	DASHBOARD ASY, SPE BATTERY GAUGE
9	260589	1	PANEL, LUMINA 20 E-STOP
10	260605	1	LUMINA 20" ANDERSON PLUG BRK'T
11	670093	1	SPRING, COMPRESSION
12	710178	2	SCR-MC 1/4-20 X .50 TRUSS STPL
13	710180	2	SCR-MC TR HD 1/4-20x.75 STL ZINC
14	710195	6	SCR-MC 5/16-18 X .50
15	710207	6	SCR-MC 6-32 X .87 ZINC
16	710534	2	SCR-MC TR HD 8-32 X 1.00 SS
17	711004	2	SK-CUP PT 1/4-20 X .25 STL BLACK
18	711160	8	#10 X 5/8 HI-LO
19	711210	2	BLT-HH 1/4-20 X 1.25 STPL
20	711310	1	NUT, HEX 10-32 ST PL
21	711372	2	NUT-NYLOC 8-32 STL ZINC
22	711425	3	NUT, HEX 1/4-20 WIZNUT
23	711430	3	NUT-TINNERMAN TWIN 6-32
24	711505	2	WSR-FLAT 1/4
25	711534	1	WSR-EXTERNAL LOCK #10
26	711544	4	WSR-HELICAL 1/4
27	711721	6	RET RING-E TYPE .312
28	712540	8	SCR-MC TR HD 10-24 X .37 SS
29	712569	1	SCR-MC TR HD 1/4-20 X 1.50 SS
30	713002	2	BLT-HH 1/4-20 UNC-2A X 3/4 STL#5
31	715589	1	DECAL, PANEL COVER
32	740147	1	CB 175 GRAY HOUSING
33	740803-1	1	SPEED CONTROL 36V 1203A-304
34	740946	1	POTENTIOMETER 5K
35	742202	1	EMERGENCY STOP SWITCH
36	742472	1	SWITCH
37	743832	1	WIRE ASSEMBLY
38	743966	1	WIRE ASY, GREEN/YELLOW 16G
39	747016-1	1	LED ASSY RED
40	805637	1	SCR INSULATOR
41	809874	1	KNOB, SPEED CONTROL
42	829052	4	BUSHING FLANGED NYLON .312 ID
43	200104MCH	1	HANDLE CONSOLE 200
44	200181CTD	2	HANDLE WIRE COATED
45	200190CTD	1	LEVER, SWITCH
46	833329SA	2	SWITCH, DPDT STAGGERED ACTION

Dashboard Assembly

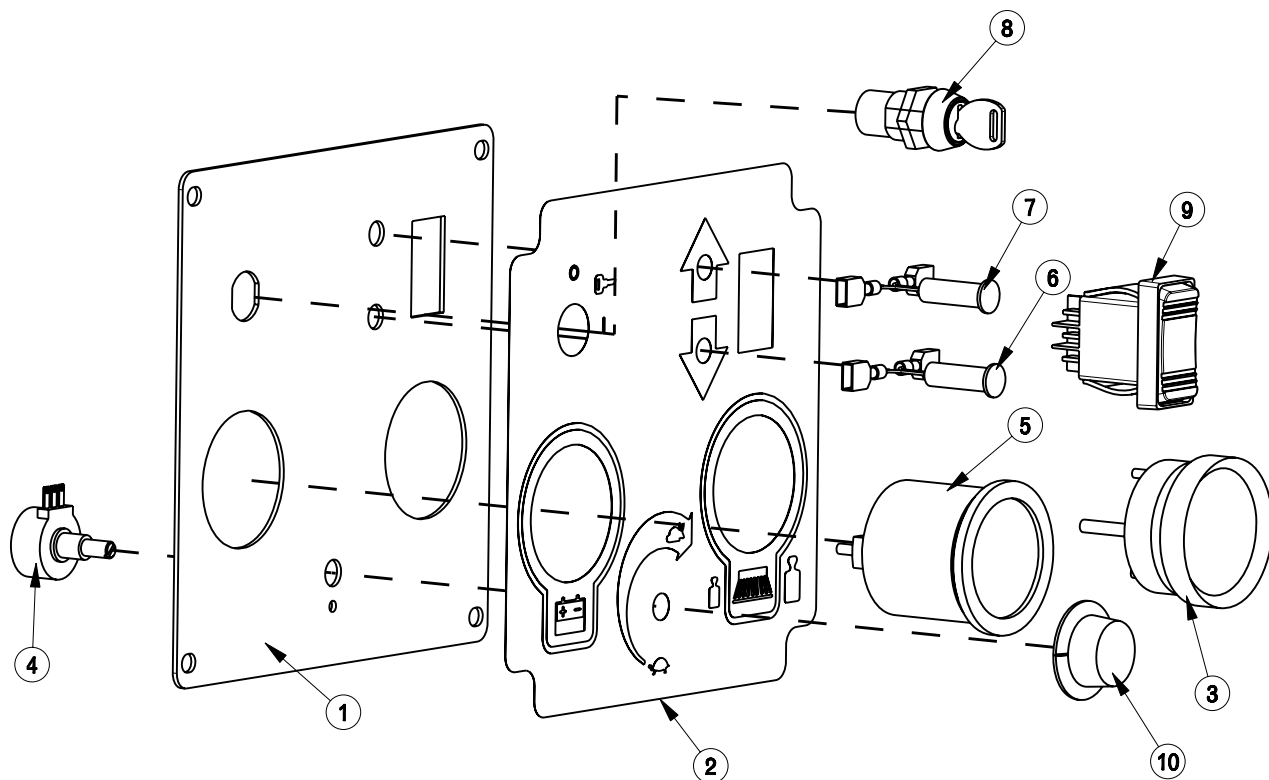

BILL OF MATERIAL - 743830-1			
ITEM	PART NO.	REQ'D	DESCRIPTION
1	260506-1	1	PLATE, DASHBOARD
2	715440	1	DECAL, DASHBOARD
3	740135	1	METER, 100A DC (PRESSURE)
4	740946	1	POTENTIOMETER 5K
5	746103	1	GAUGE, BATTERY/HOUR W/RELAY
6	747016-1	1	LED ASSY RED
7	747017-1	1	LED ASSY AMBER
8	747024	1	KEYSWITCH, SPST ES2832 SOLDER
9	748151	1	SWITCH, ON-ON, DPDT
10	809874	1	KNOB, SPEED CONTROL

Wiring Diagram

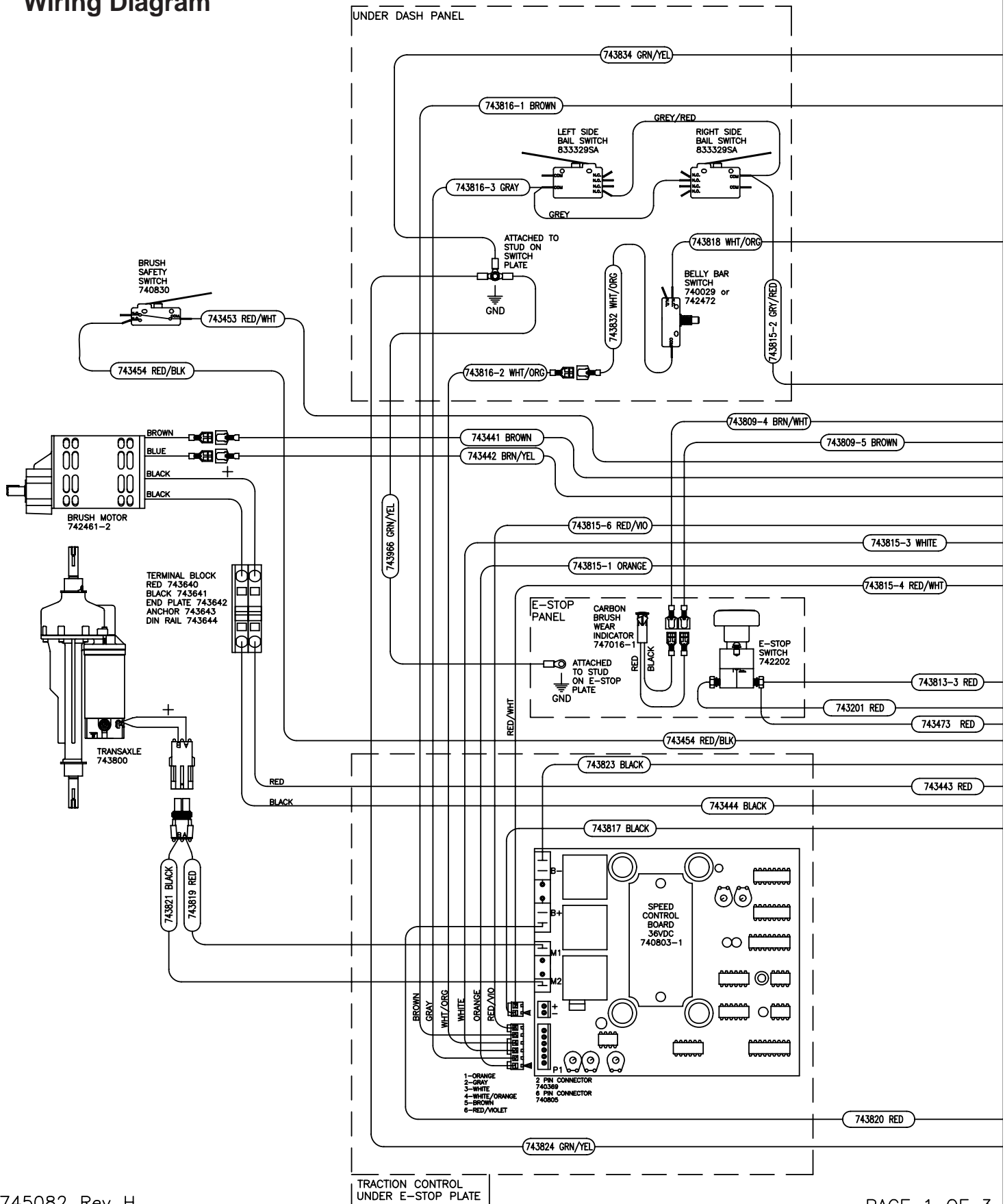

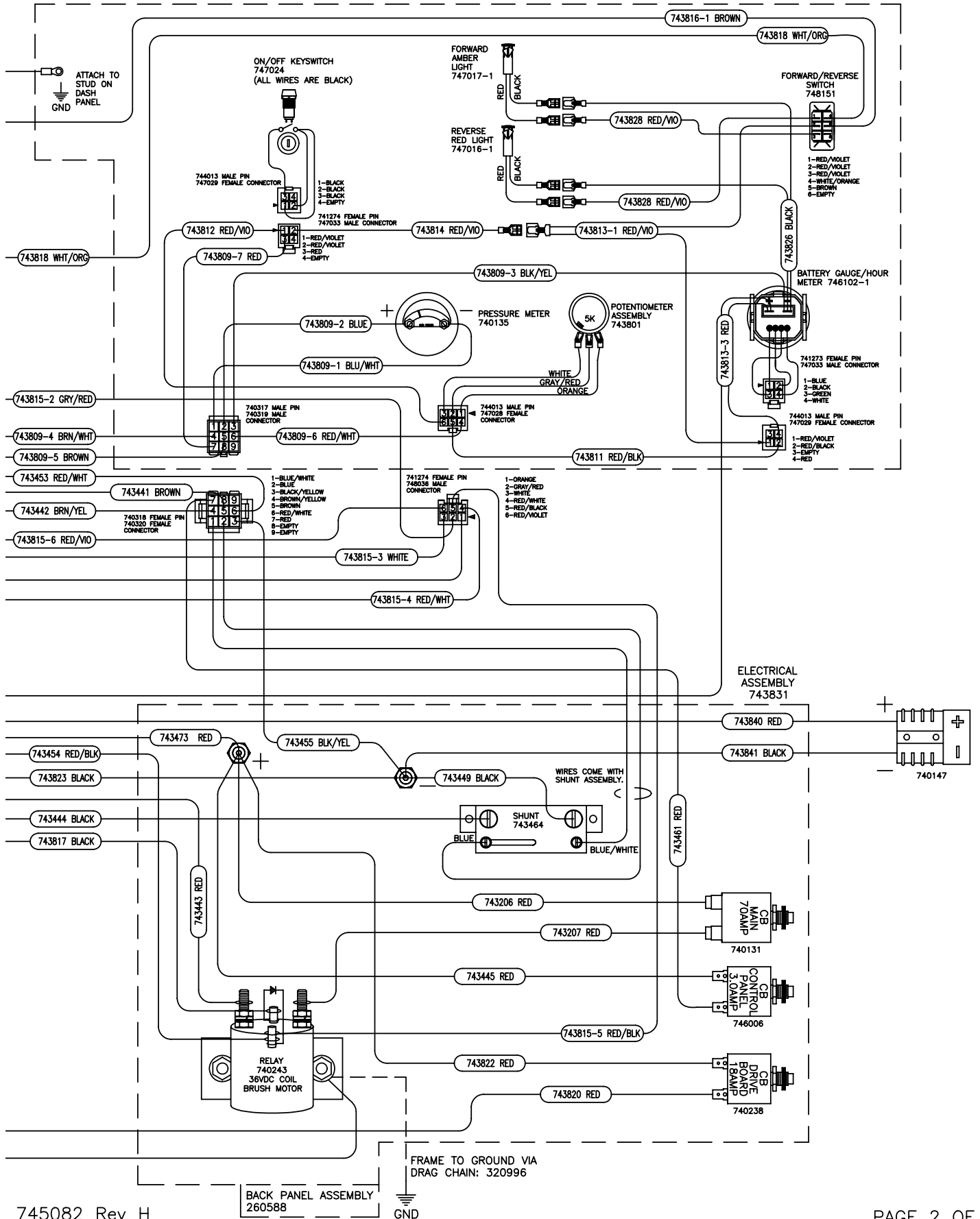

745082 Rev H

BACK PANEL ASSEMBLY
260588

FRAME TO GROUND VIA
DRAG CHAIN: 320996

GND

FROM KEY SWITCH: 747024

PIN #	COLOR	FUNCTION
1	BLACK	TOGETHER WITH 2
2	BLACK	TOGETHER WITH 1
3	BLACK	ONE WIRE FROM 9 PIN:7 FROM 3A CB
4	EMPTY	-

TO KEY SWITCH

PIN #	HARNESS COLOR	FUNCTION
1	RED/VIOLET	POSITIVE TO 6 PIN:6 TO TRACTION BOARD
2	RED/VIOLET	POSITIVE TO FOR LEDS TO REV SWITCH
3	RED	POSITIVE FROM 9 PIN:7 FROM 3A CB
4	EMPTY	-

FROM BATTERY GAUGE: 746102-1

PIN #	COLOR	FUNCTION
1	BLUE	KEY SWITCH ON/OFF LED
2	BLACK	START HOUR METER
3	GREEN	24V SYSTEM
4	WHITE	36V SYSTEM

TO BATTERY GAUGE: 743813

PIN #	COLOR	FUNCTION
1	RED/VIOLET	KEY SWITCH ON/OFF LED
2	RED/BLACK	START HOUR METER
3	EMPTY	-
4	RED	36V SYSTEM

REVERSE SWITCH: 748000

PIN #	COLOR	FUNCTION
1	RED/VIOLET	REVERSE LED POSITIVE(RED)
2	RED/VIOLET	KEY SWITCH ON/OFF
3	RED/VIOLET	FORWARD LED POSITIVE(RED)
4	WHITE/ORANGE	BELLY SWITCH-CONTROL 6 PIN:4/REVERSE TRACTION
5	BROWN	CONTROL 6 PIN:5/REVERSE TRACTION
6	EMPTY	-

6 PIN CONNECTOR: DASH SIDE 743809

PIN #	COLOR	FUNCTION
1	ORANGE	SPEED POTENTIOMETER
2	GRAY/RED	SPEED POTENTIOMETER
3	WHITE	SPEED POTENTIOMETER
4	RED/WHITE	9 PIN: 6
5	RED/BLACK	BATTERY 4 PIN: 2
6	RED/VIOLET	KEY SWITCH 4 PIN: 1

6 PIN CONNECTOR

PIN #	COLOR	FUNCTION
1	ORANGE	CONTROL 6 PIN: 1
2	GRAY	CONTROL 6 PIN: 2
3	WHITE	CONTROL 6 PIN: 3
4	RED/WHITE	CONTROL 2 PIN: 2 + BRAKE
5	RED/BLACK	BRUSH MOTOR SOLENOID: COIL
6	RED/VIOLET	CONTROL 6 PIN:6

9 PIN CONNECTOR: DASH SIDE

PIN #	COLOR	FUNCTION
1	BLUE/WHITE	- ON PRESSURE METER
2	BLUE	+ ON PRESSURE METER
3	BLACK/YELLOW	- ON BATTERY GAUGE/HOUR METER
4	BROWN/WHITE	BRUSH WEAR INDICATOR LED NEGATIVE(BLACK)
5	BROWN	BRUSH WEAR INDICATOR LED POSITIVE(RED)
6	RED/WHITE	6 PIN:4/POSITIVE TO TURN ON MOTOR SOLENOID
7	RED	KEY SWITCH 4 PIN: 3/ POWER ON
8	EMPTY	-
9	EMPTY	-

9 PIN CONNECTOR

PIN #	COLOR	FUNCTION
1	BLUE/WHITE	SHUNT
2	BLUE	SHUNT
3	BLACK/YELLOW	OVDC POST
4	BROWN/YELLOW	BLUE ON MOTOR/BRUSH IN MOTOR 'WEAR INDICATE'
5	BROWN	BROWN ON MOTOR/BRUSH IN MOTOR 'WEAR INDICATE'
6	RED/WHITE	BRUSH SAFETY SWITCH
7	RED	3.0 AMP CIRCUIT BREAKER/ POWER TO KEY
8	EMPTY	-
9	EMPTY	-

6 PIN CONNECTOR: SPEED CONTROL BOARD

PIN #	COLOR	FUNCTION
1	ORANGE	SPEED POTENTIOMETER/ CONTROL SPEED
2	GRAY	BAIL HANDLE SWITCHES/ TURNS ON TRANSAXLE
3	WHITE	SPEED POTENTIOMETER/ CONTROL SPEED
4	WHITE/ORANGE	REVERSE SWITCH:5/ FORWARD OR REVERSE
5	BROWN	REVERSE SWITCH 6:/ FORWARD OR REVERSE
6	RED/VIOLET	KEY SWITCH ON/ ENABLES TRANSAXLE BOARD

BATTERY CONNECTION

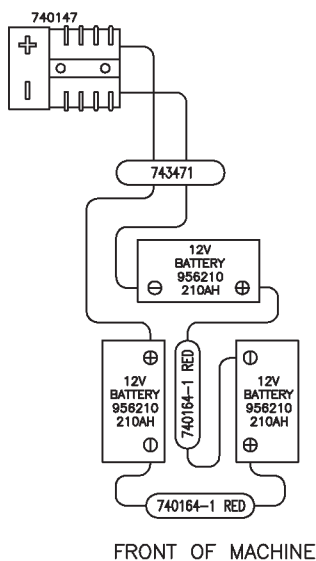

GROUNDING DIAGRAM

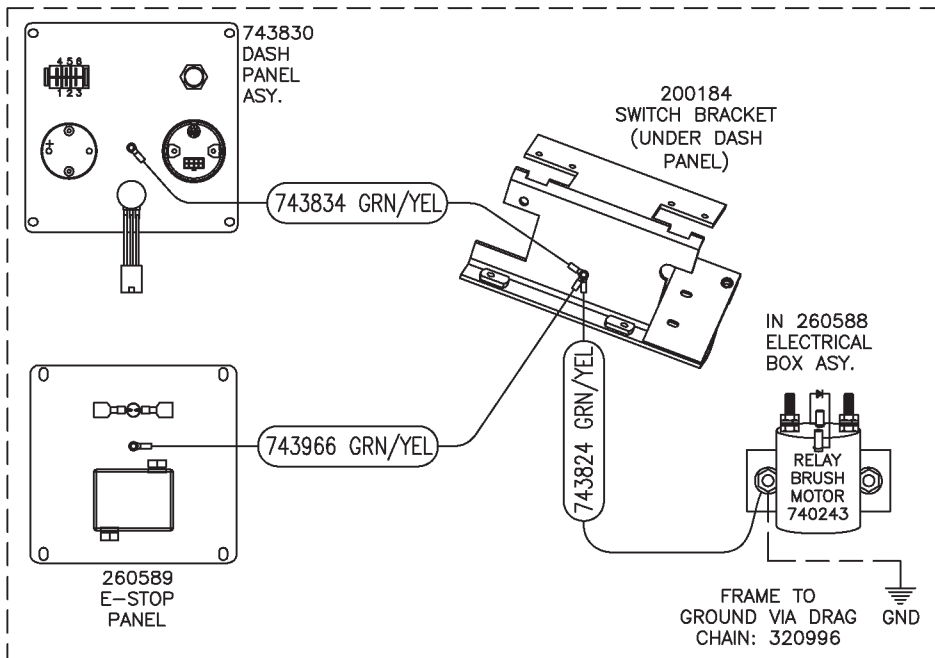

Minuteman International Made Simple Commercial Limited Warranty

Minuteman International, Inc. warrants to the original purchaser/user that the product is free from defects in workmanship and materials under normal use. Minuteman will, at its option, repair or replace without charge, parts that fail under normal use and service when operated and maintained in accordance with the applicable operation and instruction manuals. All warranty claims must be submitted through and approved by factory authorized repair stations.

This warranty does not apply to normal wear, or to items whose life is dependent on their use and care, such as belts, cords, switches, hoses, rubber parts, electrical motor components or adjustments. Parts not manufactured by Minuteman are covered by and subject to the warranties and/or guarantees of their manufacturers. Please contact Minuteman for procedures in warranty claims against these manufacturers.

Special warning to purchaser -- Use of replacement filters and/or prefilters not manufactured by Minuteman or its designated licensees, will void all warranties expressed or implied. A potential health hazard exists without original equipment replacement.

All warranted items become the sole property of Minuteman or its original manufacturer, whichever the case may be.

Minuteman disclaims any implied warranty, including the warranty of merchantability and the warranty of fitness for a particular purpose. Minuteman assumes no responsibility for any special, incidental or consequential damages.

This limited warranty is applicable only in the U.S.A. and Canada, and is extended only to the original user/purchaser of this product. Customers outside the U.S.A. and Canada should contact their local distributor for export warranty policies. Minuteman is not responsible for costs or repairs performed by persons other than those specifically authorized by Minuteman. This warranty does not apply to damage from transportation, alterations by unauthorized persons, misuse or abuse of the equipment, use of non-compatible chemicals, or damage to property, or loss of income due to malfunctions of the product.

If a difficulty develops with this machine, you should contact the dealer from whom it was purchased.

This warranty gives you specific legal rights, and you may have other rights which vary from state to state. Some states do not allow the exclusion or limitation of special, incidental or consequential damages, or limitations on how long an implied warranty lasts, so the above exclusions and limitations may not apply to you.

Cord Electric Group..... Three years parts, two years labor, ninety days travel (Not to exceed two hours)
Exceptions..... Port-A-Scrub, one year parts, six months labor
MPV 13, one year parts
MPV 14 and 18, two years parts, one year labor
RapidAir blower, one year parts, one year labor
Explosion-Proof Vacuum, one year parts, one year labor
Pneumatic Vacuums, three years parts, one year labor
EX 12 and EX12H, one year parts, one year labor

Battery Operated Group..... Three years parts, two years labor, ninety days travel
(Not to exceed two hours)
Exceptions..... Sweepers, one year parts, one year labor, ninety days travel
(Not to exceed two hours)

Internal Combustion Group....One year parts, one year labor, ninety day travel
(Not to exceed two hours)

Replacement Parts.....Ninety days
Batteries.....0-3 months replacement, 4-12 months pro-rate
Polypropylene Plastic Tanks...Ten years, no additional labor